

Designer Door Bars.Com

The 'All in one Bar'

2mm - 4.5mm LVT to Carpet

2mm - 4.5mm LVT to Higher Surface

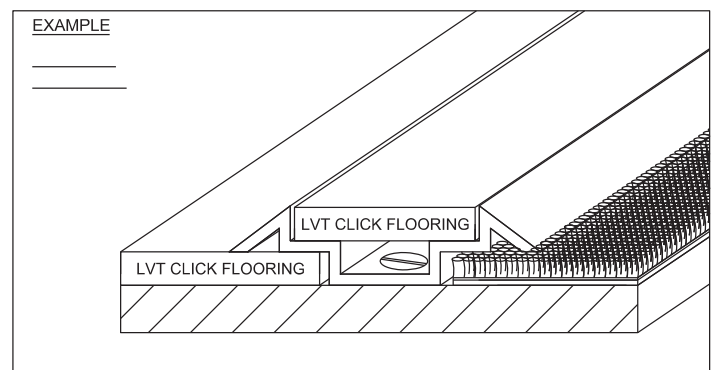
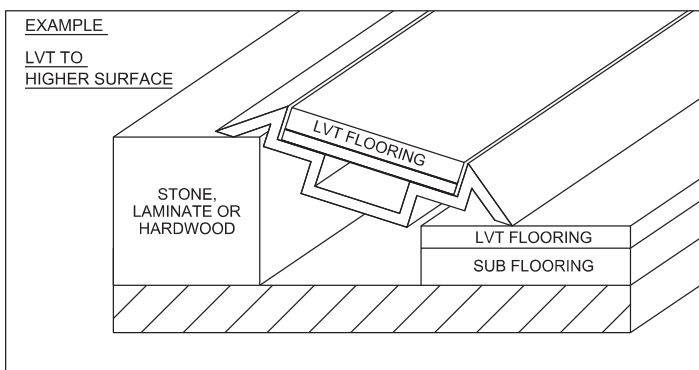
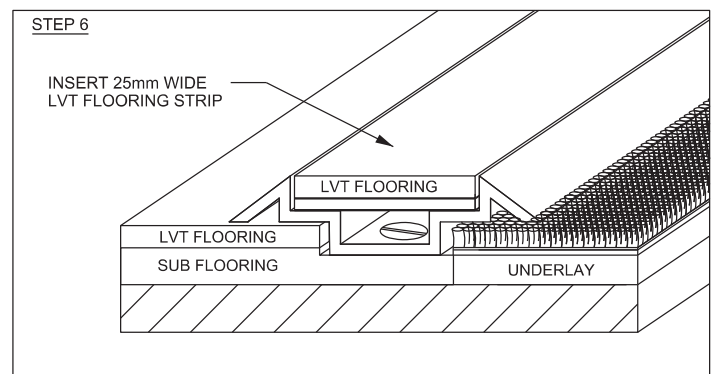
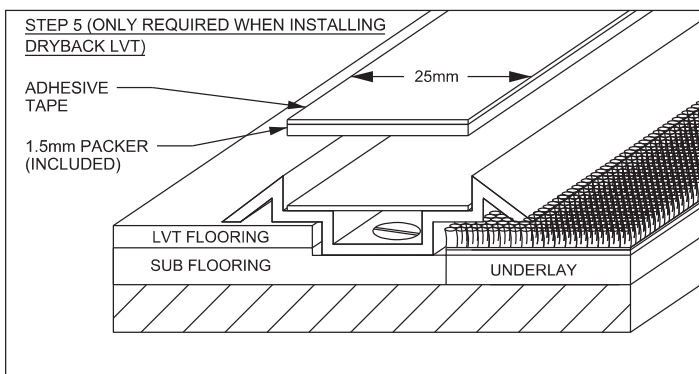
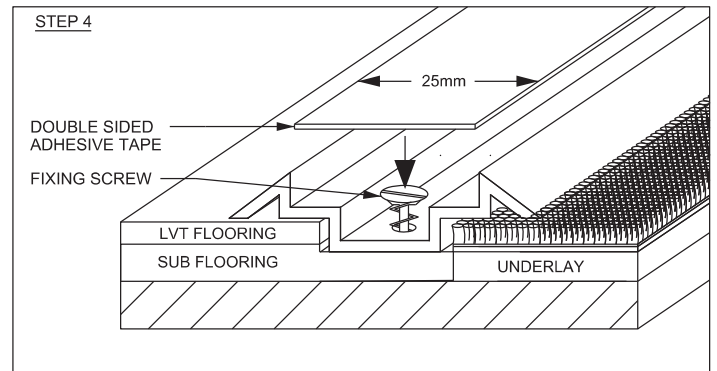
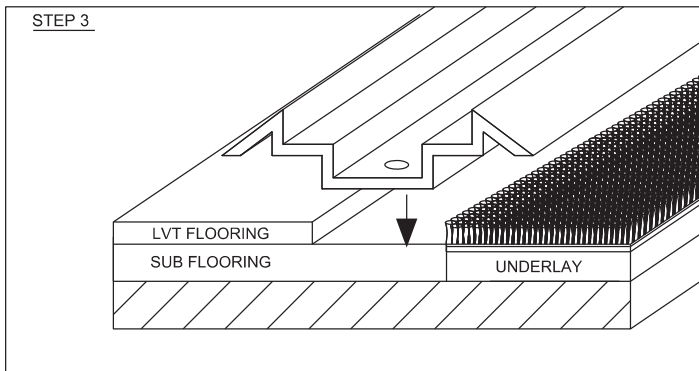
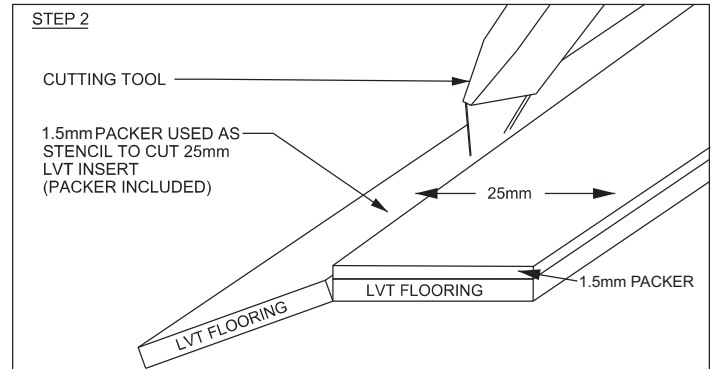
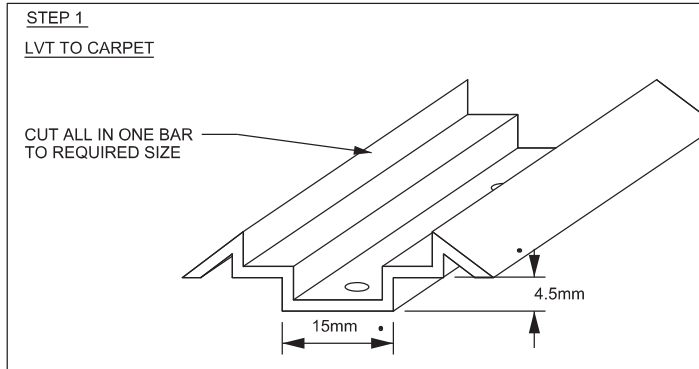

*All fixings included, screws, tape, universal plugs

Designer Door Bars.Com

“Sales Pitch”

To help you to sell the ‘All in one Bar’ profile too your client's

Mr. or Mrs. Customer, now how would you like to finish off your
NEW Karndean / Amtico / Moduleo / Lvt floor covering

Would you like a Brass or Silver bar?

or one that now

Perfectly matches your NEW floor ?

“Top Tip”

Please take care not to over tighten the profile.

A medium torque is all that it is required.

Best regards to you, Simon Wynn.